

# Unigestone

5 COLOURS

6 SIZES

3 SURFACES

A collection inspired by the aesthetics of different stones, granites and marbles, skilfully mixed together liven up the style of every environment, whether residential or commercial.

Una collezione ispirata all'estetica di pietre, graniti e marmi differenti sapientemente miscelati tra di loro per muovere con carattere lo stile di ogni ambiente, residenziale o commerciale.

Eine am aussehen verschiedener und auf gelungene Weise miteinander kombinierter Steine, Granite und Marmorarten inspirierte Kollektion. Bringt stilvoll Bewegung und Charakter in jeden Gewerbe- oder Wohnraum.

Une collection qui puise son inspiration a l'esthétique de la pierre. Plusieurs types de granits et de marbres savamment mélangés apportent une note authentique de caractère à tout espace de vie, à usage privatif ou commercial.

## Unigestone

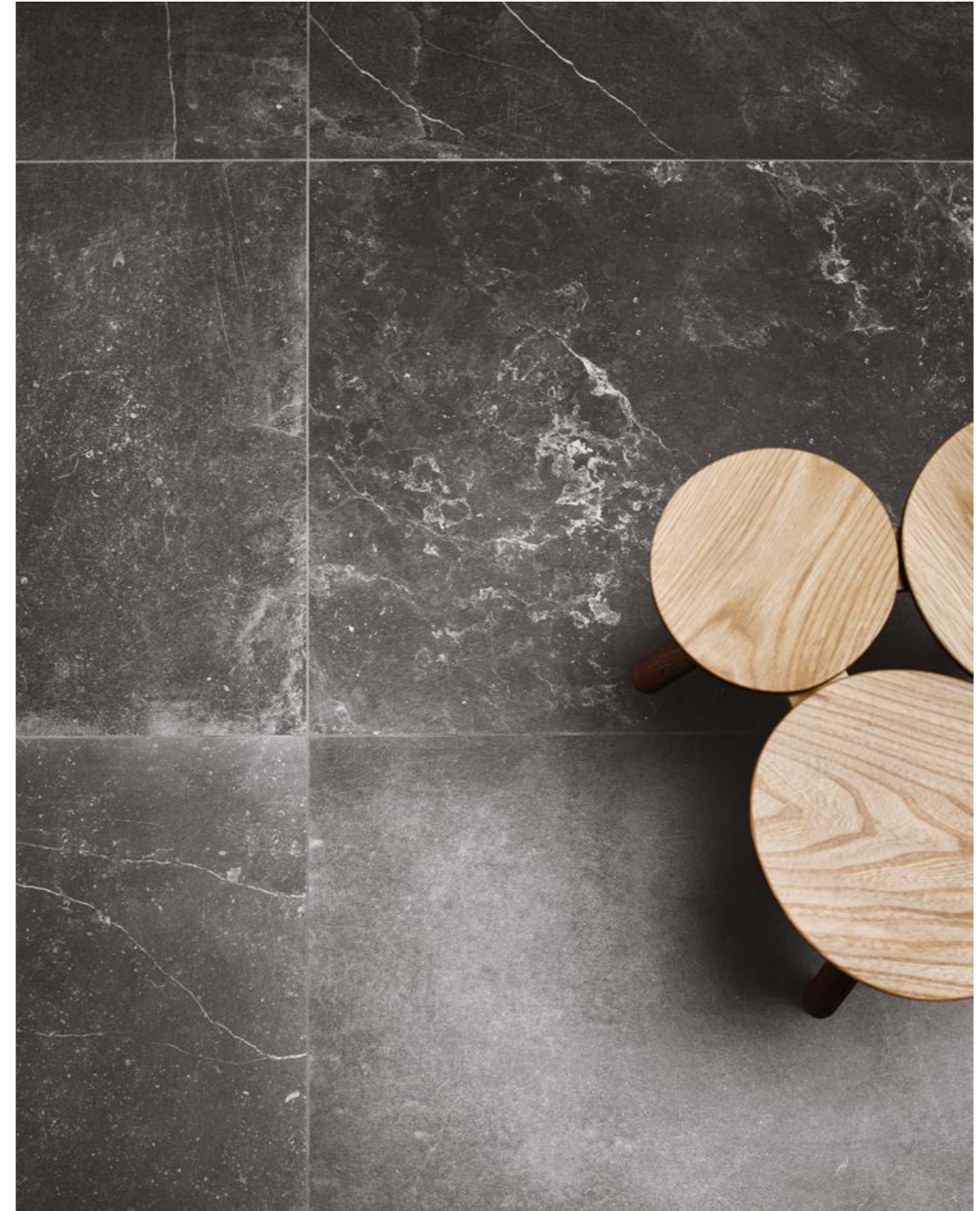

Spazi Residenziali  
Residential Spaces

P. 5

Spazi Pubblici  
Public Areas

P. 21

Informazioni Tecniche  
Technical Information

P. 37

La superficie della materia è caratterizzata da uno stonalizzo grafico ben bilanciato da un tono di fondo morbido ed omogeneo per un risultato finale molto equilibrato nella sua variabilità. Disponibile in cinque varianti cromatiche in finitura naturale e levigata è ideale per rivestire ambienti interni ed esterni ad alto impatto emozionale.

The material surface is characterized by well-balanced graphic colour and by a soft and uniform colour background for an end result which is very stable in its variability. Available in five different colours in natural and polished finish, it is perfect for covering interior and outdoor environments with high emotional impact.

Die Oberfläche des Materials ist durch grafische Nuancierungen geprägt, die durch eine weiche und gleichmässige Grundnote ausgeglichen werden. Das sorgt für einen trotz der Variabilität harmonischen Gesamteindruck. In fünf Farbvarianten jeweils mit Oberfläche natur und Poliert erhältlich. Ideal zur Verkleidung von Innen- und Außenbereichen von hoher Emotionaler Wirkung.

La surface de la matière est caractérisée par un dénuancement graphique bien équilibré, sur un fond au ton doux et homogène, pour aboutir à une variabilité parfaitement maîtrisée. Disponible en cinq variantes chromatiques, finition naturelle et polie, c'est un revêtement idéal pour l'intérieur et l'extérieur à fort impact émotionnel.

# Spazi Residenziali

Residential Spaces  
Wohnanlagen  
Espaces Résidentiels

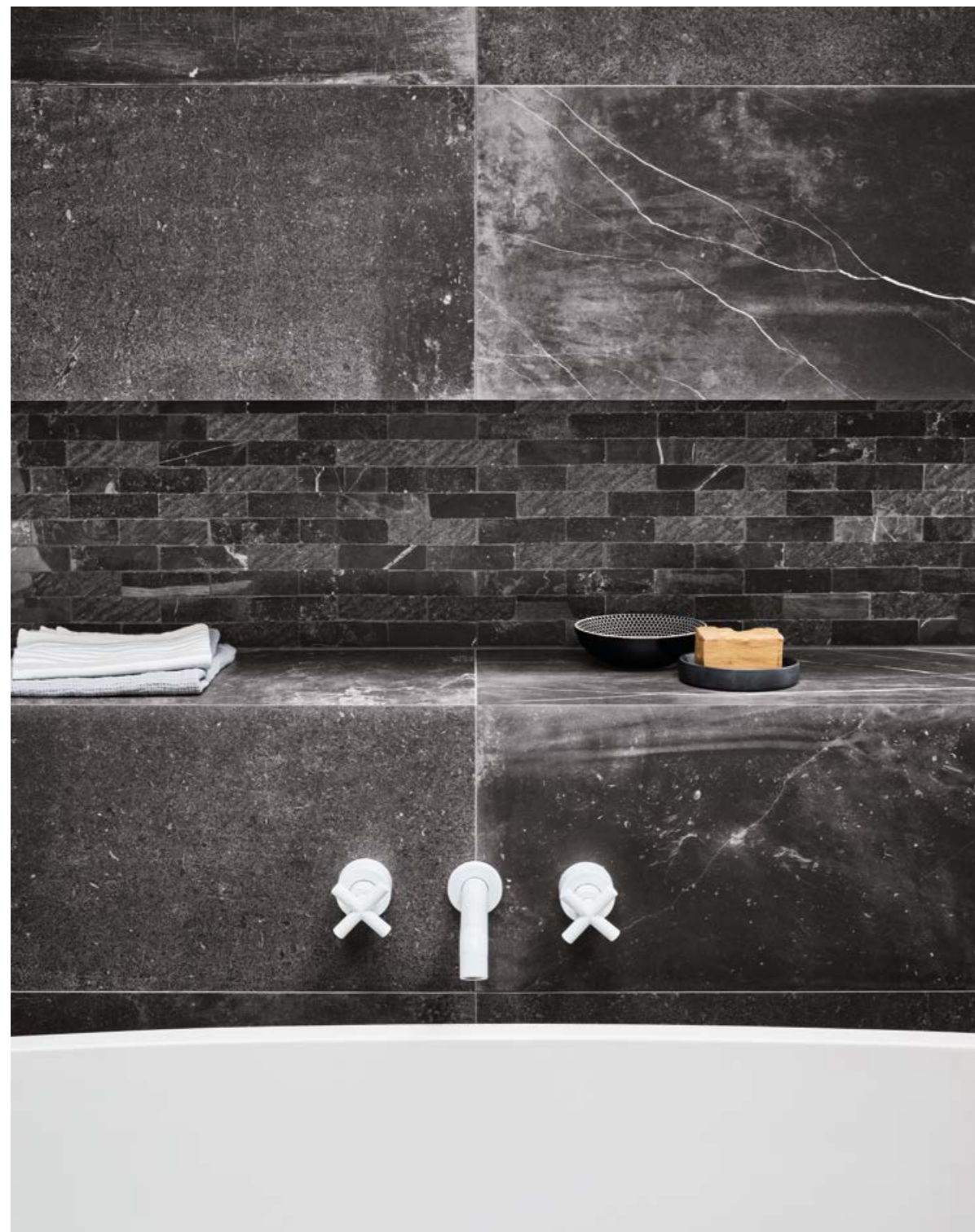

COLORI / COLOURS

AMBIENTI / AMBIENT

PAGINA / PAGE

Nite	Bathroom	6
Titanium	Bedroom	10
Sand	Kitchen	14
Silver	Entrance	17
Silk	Living	18

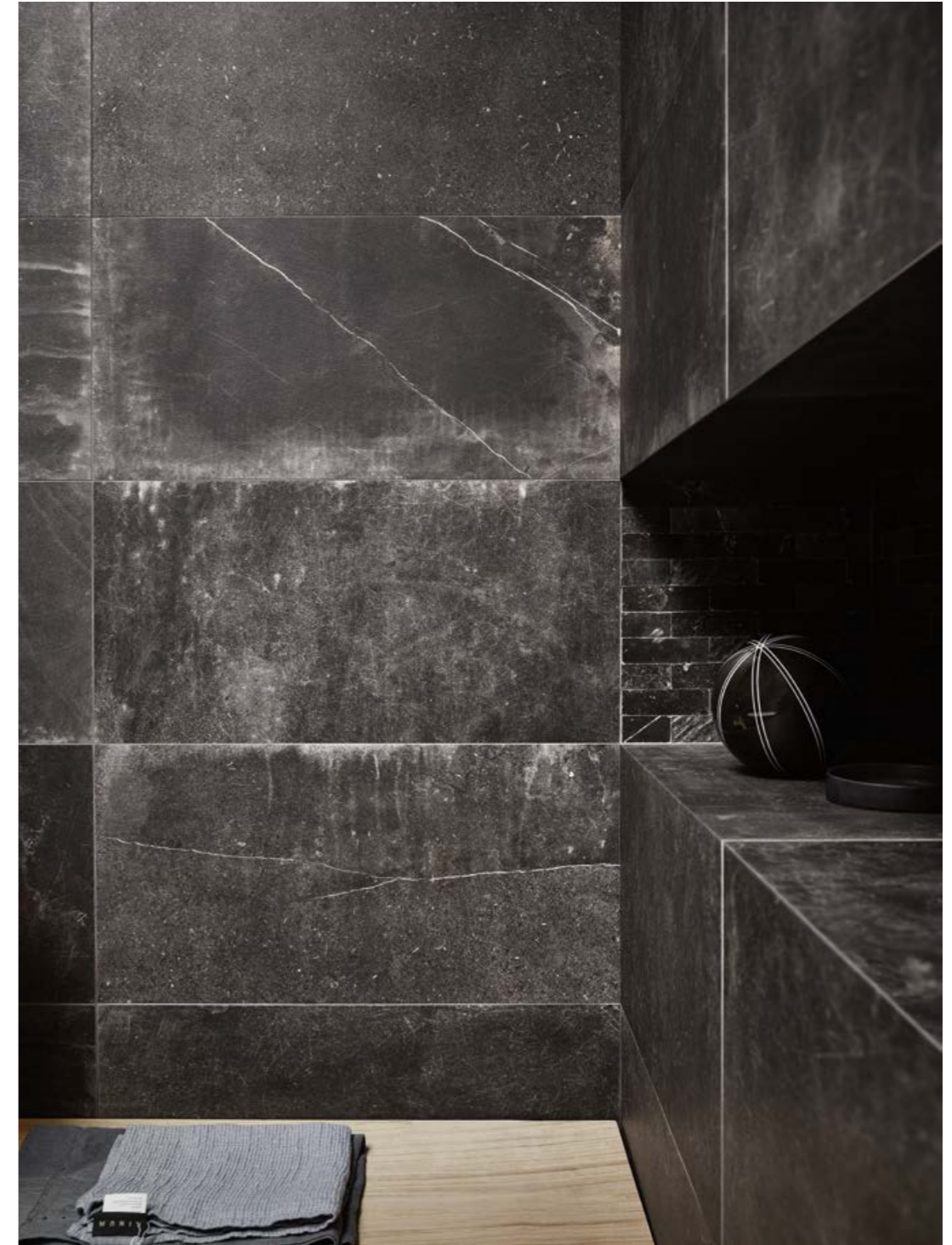











## Silver

The result is a tile which, depending on how it is interpreted, can be used in environments characterised by various styles, from classic to contemporary and eclectic.

Ein Erzeugnis, das je nach Auslegung für verschiedene Stilarten von Klassik bis Modern bis hin zum Eklektizismus geeignet ist.

En fonction de l'interprétation qu'on lui donne, ce produit pourra être décliné sur une grande variété de styles, du classique au contemporain en passant par l'éclectique.

Un prodotto che a seconda dell'interpretazione può essere declinato in varie tipologie di stile, dal classico al contemporaneo, all'eclettico.

30x60 - 12"x24" Naturale Rettificato



Uniquestone  
Residential Spaces



# Spazi Pubblici

Public Areas  
Öffentliche Räumlichkeiten  
Espaces Publics



COLORI / COLOURS

AMBIENTI / AMBIENT

PAGINA / PAGE

Silk	Shop	22
Sand	Hall	27
Silver	Airport Lounge	28
Titanium	Boutique Hotel	32
Nite	Restaurant	34

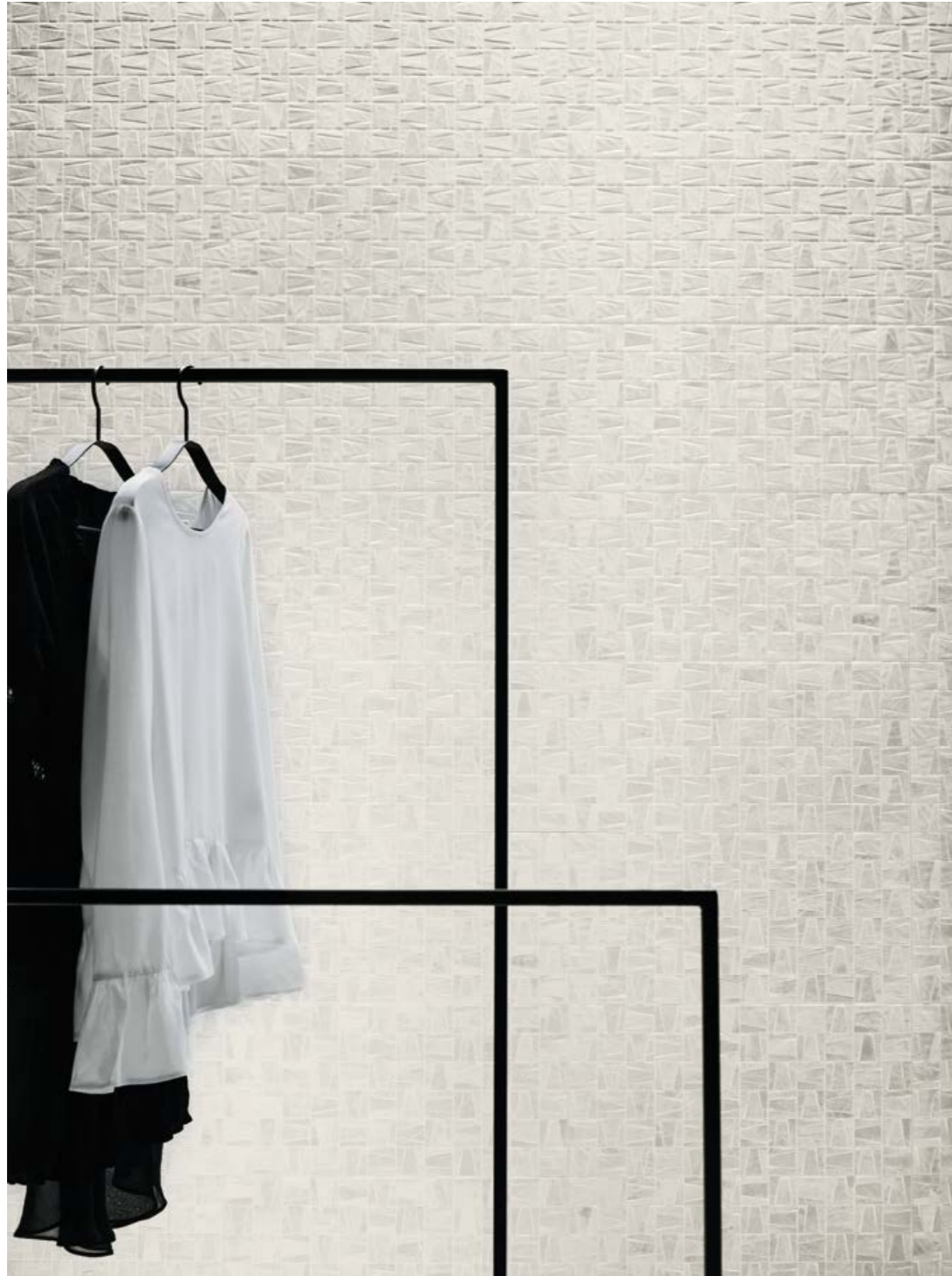



## Sand

It is extremely “transversal”, thanks to its flexibility and the fact that it can be matched and paired with materials of different kinds, “adaptable” due to the possibilities it offers when it comes to interpreting different styles and “versatile” as it can be used to meet a wide variety of design requirements.

Sehr “zweckübergreifend” dank seiner Vielseitigkeit, Kombinationen und Zusammenstellungen mit verschiedenartigen Materialien; “mannigfaltig”, weil es sich mit unterschiedlichen Stilen interpretieren lässt; “vielseitig” für die jeweiligen Entwurfsbedürfnisse.

Sa polyvalence le rend vraiment “transversal”; il peut être associé à des matériaux de nature différente, s’adapte à des styles divers et se plie aux contraintes de la conception.

Altamente “trasversale”, grazie alla sua flessibilità, abbinamenti e accostamenti con materiali di natura differente, “duttile” per la possibilità che offre di interpretazione con stili differenti, “versatile” alle differenti necessità di progettazione.

80×80 - 31½”×31½” Levigato Rettificato









## Titanium

It is an intrinsically sustainable material yet at the same time flaunts a highly sophisticated charm thanks to the technology used to create it.

Das Material ist dank seiner Beschaffenheit nachhaltig und seiner Fertigungstechnologie gleichzeitig auch reich an ausgefeilter Eleganz.

De par sa nature, c'est un matériel écologique qui possède néanmoins un charme très sophistiqué dû à la technologie adoptée pour sa réalisation.

Un materiale sostenibile per la sua stessa natura ed al contempo ricco di un fascino altamente sofisticato grazie alla tecnologia utilizzata per la sua realizzazione.

60x60 - 24"x24" Naturale Rettificato



Uniquestone  
Public Areas

## Nite

Unigestone is the result of ongoing research and experimentation process. This has generated a product that closely resembles the spontaneous, irregular graphic look of the natural materials to which it is inspired.

Unigestone ist das Ergebnis ständiger Recherchen und Versuche, die ein Produkt hervorbrachten, das eine große Ähnlichkeit mit dem spontanen, ungleichmäßigen Aussehen der natürlichen Materialien hat, an denen es inspiriert ist.

Unigestone est le fruit d'une recherche ininterrompue. Celle-ci a donné vie à un produit très proche de la représentation graphique, spontanée et irrégulière, des matériaux naturels dont il s'inspire.

Unigestone è il frutto di una ricerca di continua sperimentazione che ha generato un prodotto molto vicino alla spontanea ed irregolare rappresentazione grafica dei materiali naturali cui si ispira.

80x80 - 31½"x31½" Levigato Rettificato



Unigestone  
Public Areas

# Informazioni Tecniche

## 5

Colori  
Colours  
Farben  
Couleurs

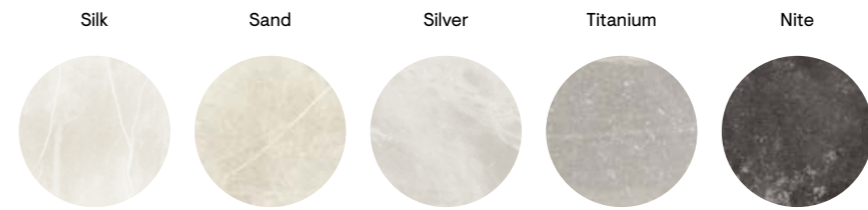

## 6

Formati  
Sizes  
Formate  
Formats

120×120 48"×48"	60×120 24"×48"	80×80 31½"×31½"	60×60 24"×24"	30×60 12"×24"	10×53 4"×20"
--------------------	-------------------	--------------------	------------------	------------------	-----------------

## 2

Spessori  
Thickness  
Stärke  
Épaisseur

±9      ±9,5

## 3

Superfici  
Surfaces  
Oberflächen  
Surfaces

Naturale      Levigato      Bocciardato

## 3

Strutture 3D  
3D structures  
Strukturen  
Décorations en relief

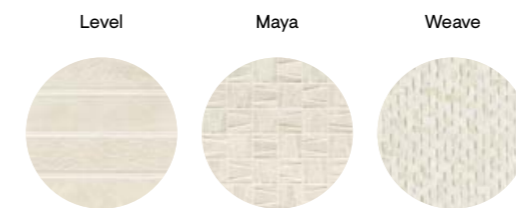

## i

Effetto Pietra Stone Look Natursteinoptik Effet Pierre	Rivestimento Wall Tiles Wandfliesen Revêtement	Pavimento Floor Tiles Bodenfliesen Sol	Gres fine porcellanato ad impasto colorato Coloured-body fine porcelain stoneware Feinsteinzeug aus farbiger Masse Grès cérame fin à pâte colorée	Tecnologia digitale Digital technology Digital technologie Technologie numérique
---	---	---	--	---

Ripresa grafica tra le diverse lastre rettificata contenuta entro le tolleranze previste dalla norma. Per un corretto allineamento si consiglia di utilizzare una fuga di 2 mm.  
Graphic representation between the rectified tiles is contained within the tolerances provided by the standard. For a correct alignment it is recommended to use a 2 mm joint.  
Grafische Darstellung zwischen den verschiedenen rektifizierten Platten innerhalb der in der Norm vorgesehenen Toleranzen. Für eine korrekte Anpassung wird eine Fuge von 2mm empfohlen.  
Reproduction graphique entre les différents carreaux rectifiés dans les limites des tolérances prévues par la norme. Pour un alignement correct, il est recommandé d'utiliser joints de 2 mm.



# Silk



± 9

120×120 - 48"×48"

**05295** | Unique Silk Nat/Ret



± 9,5

80×80 - 31½"×31½"

**03639** | Unique Silk Nat/Ret U4 P3 E3 C2  
**03641** | Unique Silk Lev/Ret



± 9,5

60×60 - 24"×24"

**01702A** | Unique Silk Nat/Ret U4 P4 E3 C2  
**01691A** | Unique Silk Lev/Ret

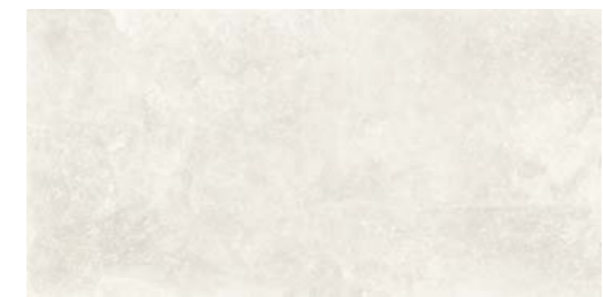

± 9,5

60×120 - 24"×48"

**02995A** | Unique Silk Nat/Ret U4 P3 E3 C2  
**02999A** | Unique Silk Lev/Ret  
**03003A** | Unique Silk Bocciardato Ret



± 9,5

30×60 - 12"×24"

**01707A** | Unique Silk Nat/Ret U4 P3 E3 C2  
**01696A** | Unique Silk Lev/Ret

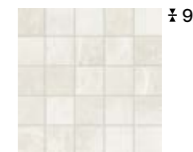

± 9,5

30×30 - 12"×12"

**01771** | Unique Silk Mosaico Nat/Ret



± 9,5

30×30 - 12"×12"

**01786** | Unique Silk Mix All In Ret



± 9,5

60×120 - 24"×48"

**03008A** | Unique Silk Level Ret



± 9,5

10×53 - 4"×20"

**01792** | Unique Silk Chevron Nat/Ret U4 P3 E3 C2



± 9,5

30×60 - 12"×24"

**01785A** | Unique Nite Maya Design Ret

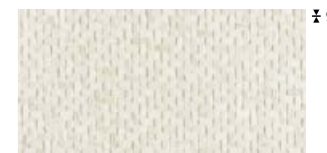

± 9,5

30×60 - 12"×24"

**01918A** | Unique Weave Sk/Sd Nat/Ret

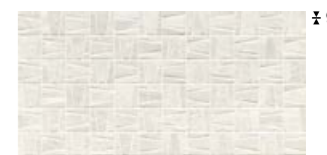

± 9,5

30×60 - 12"×24"

**01781A** | Unique Silk Maya Ret

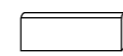



# Sand



120×120 - 48"×48"  
**05296** | Unique Sand Nat/Ret



80×80 - 31½"×31½"  
**03684** | Unique Sand Nat/Ret U4 P3 E3 C2  
**03867** | Unique Sand Lev/Ret



60×60 - 24"×24"  
**01703A** | Unique Sand Nat/Ret U4 P4 E3 C2  
**01692A** | Unique Sand Lev/Ret



60×120 - 24"×48"  
**02996A** | Unique Sand Nat/Ret U4 P3 E3 C2  
**03000A** | Unique Sand Lev/Ret  
**03004A** | Unique Sand Bocciardato Ret



30×60 - 12"×24"  
**01708A** | Unique Sand Nat/Ret U4 P3 E3 C2  
**01697A** | Unique Sand Lev/Ret



30×30 - 12"×12"  
**01772** | Unique Sand Mosaico Nat/Ret



30×30 - 12"×12"  
**01787** | Unique Sand Mix All In Ret



60×120 - 24"×48"  
**03009A** | Unique Sand Level Ret



10×53 - 4"×20"  
**01793** | Unique Sand Chevron Nat/Ret U4 P3 E3 C2



30×60 - 12"×24"  
**01918A** | Unique Weave Sk/Sd Nat/Ret



30×60 - 12"×24"  
**01785A** | Unique Nite Maya Design Ret



30×60 - 12"×24"  
**01782A** | Unique Sand Maya Ret

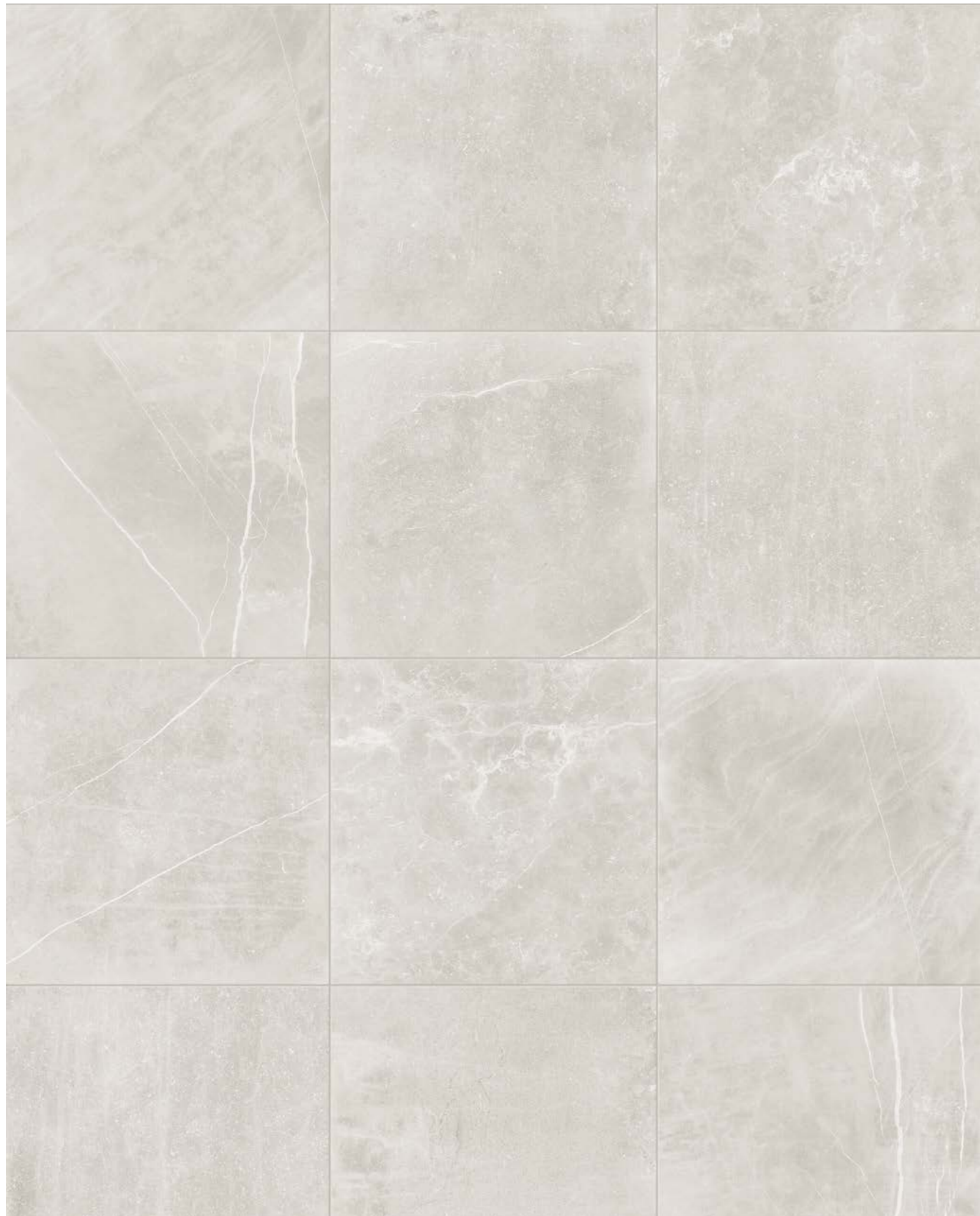

# Silver



80×80 - 31½"×31½"  
**03642** | Unique Silver Nat/Ret U4 P3 E3 C2  
**03643** | Unique Silver Lev/Ret



60×60 - 24"×24"  
**01704A** | Unique Silver Nat/Ret U4 P4 E3 C2  
**01693A** | Unique Silver Lev/Ret



30×30 - 12"×12"  
**01773** | Unique Silver Mosaico Nat/Ret



60×120 - 24"×48"  
**02997A** | Unique Silver Nat/Ret U4 P3 E3 C2  
**03001A** | Unique Silver Lev/Ret  
**03005A** | Unique Silver Bocciardato Ret



30×60 - 12"×24"  
**01709A** | Unique Silver Nat/Ret U4 P3 E3 C2  
**01698A** | Unique Silver Lev/Ret



30×30 - 12"×12"  
**01788** | Unique Silver Mix All In Ret



10×53 - 4"×20"  
**01794** | Unique Silver Chevron Nat/Ret U4 P3 E3 C2



30×60 - 12"×24"  
**01917A** | Unique Weave Tm/Sr Nat/Ret



60×120 - 24"×48"  
**03010A** | Unique Silver Level Ret



30×60 - 12"×24"  
**01785A** | Unique Nite Maya Design Ret



30×60 - 12"×24"  
**01783A** | Unique Silver Maya Ret



# Titanium

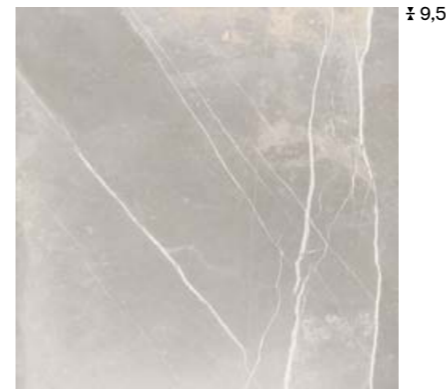

80×80 - 31½"×31½"  
**03637** | Unique Titanium Nat/Ret U4 P3 E3 C2  
**03638** | Unique Titanium Lev/Ret



60×60 - 24"×24"  
**01705A** | Unique Titanium Nat/Ret U4 P4 E3 C2  
**01694A** | Unique Titanium Lev/Ret



30×30 - 12"×12"  
**01774** | Unique Titanium Mosaico Nat/Ret



60×120 - 24"×48"  
**02976A** | Unique Titanium Nat/Ret U4 P3 E3 C2  
**02977A** | Unique Titanium Lev/Ret  
**03006A** | Unique Titanium Bocciardato Ret



30×60 - 12"×24"  
**01711A** | Unique Titanium Nat/Ret U4 P3 E3 C2  
**01699A** | Unique Titanium Lev/Ret



30×30 - 12"×12"  
**01789** | Unique Titanium Mix All In Ret



10×53 - 4"×20"  
**01795** | Unique Titanium Chevron Nat/Ret U4 P3 E3 C2

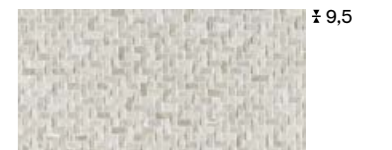

30×60 - 12"×24"  
**01917A** | Unique Weave Tm/Sr Nat/Ret



60×120 - 24"×48"  
**03011A** | Unique Titanium Level Ret



30×60 - 12"×24"  
**01785A** | Unique Nite Maya Design Ret



30×60 - 12"×24"  
**01784A** | Unique Titanium Maya Ret





# Nite



120x120 - 48"x48"  
05297 | Unique Nite Nat/Ret



80x80 - 31½"x31½"  
03617 | Unique Nite Nat/Ret U4 P3 E3 C2  
03618 | Unique Nite Lev/Ret

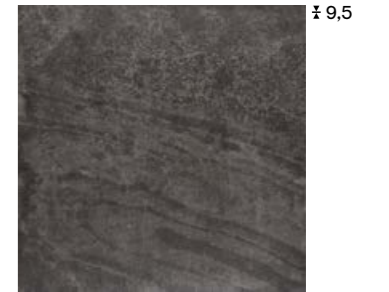

60x60 - 24"x24"  
01706A | Unique Nite Nat/Ret U4 P4 E3 C2  
01695A | Unique Nite Lev/Ret



60x120 - 24"x48"  
02998A | Unique Nite Nat/Ret U4 P3 E3 C2  
03002A | Unique Nite Lev/Ret  
03007A | Unique Nite Bocciardato Ret



30x60 - 12"x24"  
01712A | Unique Nite Nat/Ret U4 P3 E3 C2  
01701A | Unique Nite Lev/Ret

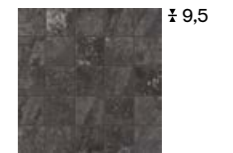

30x30 - 12"x12"  
01775 | Unique Nite Mosaico Nat/Ret



60x120 - 24"x48"  
03012A | Unique Nite Level Ret



10x53 - 4"x20"  
01796 | Unique Nite Chevron Nat/Ret U4 P3 E3 C2

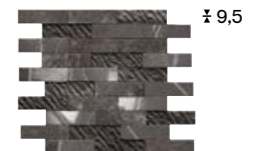









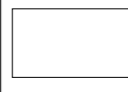
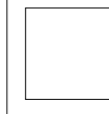

30x30 - 12"x12"  
01791 | Unique Nite Mix All In Ret



30x60 - 12"x24"  
01785A | Unique Nite Maya Design Ret





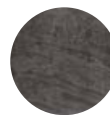

# Riepilogo Gamma

Collection  
Serie  
Gamme

	Formati Sizes							Strutture 3D 3D Structures					
		120x120 48"x48"	60x120 24"x48"	80x80 31½"x31½"	60x60 24"x24"	30x60 12"x24"	Chevron 10x53 4"x20"	DIN 51130	DIN 51097	DCOF	Level 60x120 24"x48"	Maya 30x60 12"x24"	Weave 30x60 12"x24"
		± 9	± 9,5	± 9,5	± 9,5	± 9,5	± 9,5				± 9,5	± 9,5	± 9,5
	Nat/Ret	05295	02995A	03639	01702A	01707A	01792	R10	A+B	>0.42	03008A	01781A	01918A
	Lev/Ret		02999A	03641	01691A	01696A		V3					
	Bocciardato		03003A					R11	A+B+C	>0.42			
	Nat/Ret	05296	02996A	03684	01703A	01708A	01793	R10	A+B	>0.42	03009A	01782A	01918A
	Lev/Ret		03000A	03867	01692A	01697A		V3					
	Bocciardato		03004A					R11	A+B+C	>0.42			
	Nat/Ret		02997A	03642	01704A	01709A	01794	R10	A+B	>0.42	03010A	01783A	01917A
	Lev/Ret		03001A	03643	01693A	01698A		V3					
	Bocciardato		03005A					R11	A+B+C	>0.42			
	Nat/Ret		02976A	03637	01705A	01711A	01795	R10	A+B	>0.42	03011A	01784A	01917A
	Lev/Ret		02977A	03638	01694A	01699A		V3					
	Bocciardato		03006A					R11	A+B+C	>0.42			
	Nat/Ret	05297	02998A	03617	01706A	01712A	01796	R10	A+B	>0.42	03012A	01785A	
	Lev/Ret		03002A	03618	01695A	01701A		V3					
	Bocciardato		03007A					R11	A+B+C	>0.42			

# Riepilogo Gamma

Collection  
Serie  
Gamme

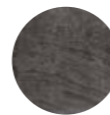
	Formati Sizes			Pezzi Speciali Special Pieces			
		Mosaico 30x30 12"x12"	Mosaico Mix All In 30x30 12"x12"	Gradino Costa Retta 33x120 13"x48"	Battiscopa 6,5x120 2½"x48"	Battiscopa 8x80 3¼"x31½"	Battiscopa 8x60 3¼"x24"
		± 9,5	± 9,5	± 9,5	± 10,5	± 10,5	± 9,5
	Nat/Ret	01771		03733A	01797	01808	01819
	Lev/Ret		01786		01803	01814	01825
	Nat/Ret	01772		03734A	01798	01809	01821
	Lev/Ret		01787		01804	01815	01826
	Nat/Ret	01773		03735A	01799	01811	01822
	Lev/Ret		01788		01805	01816	01827
	Nat/Ret	01774		03736A	01801	01812	01823
	Lev/Ret		01789		01806	01817	01828
	Nat/Ret	01775		03737A	01802	01813	01824
	Lev/Ret		01791		01807	01818	01829

Packing  
Verpackung  
Emballage

Formato / Size		± MM	Pezzi Scatola Pcs/Box Stck/Karton Carreaux/Boîtes	Mq/Scatola Sqmt/Box M2/Karton Qm/Boîtes	Kg/Scatola Kgs/Box Kg/Karton Kg/Boîtes	Scatola/Paletta Boxes/Pallet Karton/Palette Boîtes/Pallet	Mq/Paletta Sqmt/Pallet M2/Palette Qm/Pallet	Kg/Paletta Kgs/Pallet Kg/Palette Kg/Pallet	Formato Paletta Size Pallet Format Palette Dim. Palette
120x120 (48"x48") Nat/Ret	P	9	2	2,88	58,00	22	63,36	1276	143x126x67
60x120 (24"x48") Nat/Ret	P	9,5	2	1,44	31,00	30	43,20	930	122x80x96
60x120 (24"x48") Lev/Ret	P	9,5	2	1,44	32,00	30	43,20	960	122x80x96
60x120 (24"x48") Bocciardato Ret - Level Ret	P	9,5	2	1,44	31,00	30	43,20	930	122x80x96
80x80 (31½"x31½") Nat/Ret - Lev/Ret	P	9,5	2	1,280	27,50	50	64,00	1375	124x80x96
60x60 (24"x24") Nat/Ret	P	9,5	4	1,44	29,00	32	46,08	928	120x80x75
60x60 (24"x24") Lev/Ret	P	9,5	4	1,44	30,00	32	46,08	960	120x80x75
30x60 (12"x24") Nat/Ret	P	9,5	7	1,26	25,30	40	50,40	1012	120x80x75
30x60 (12"x24") Lev/Ret	P	9,5	7	1,26	26,30	40	50,40	1052	120x80x75
30x60 (12"x24") Maya Ret	P	9,5	7	1,26	25,30	32	40,32	809,6	120x80x75
30x60 (12"x24") Weave Nat/Ret	P	9,5	7	1,26	25,30	32	40,32	809,6	120x80x75
10x53 (4"x20") Chevron Nat/Ret	P	9,5	12	0,636	13,20	60	38,16	792	120x80x75
30x30 (12"x12") Mosaico Nat/Ret	P	9,5	5	0,450	8,50	60	-	-	-
30x30 (12"x12") Mosaico All In Ret	P	9,5	6	0,540	10,20	54	-	-	-
Pezzi Speciali / Special Pieces									
33x120 (13"x48") Gradino costa retta Nat/Ret	P	9,5	2	0,792	18,50	20	-	-	-
8x60 (3½"x24") Battiscopa Nat/Ret	P	9,5	10	0,480	11,00	72	-	-	-
8x60 (3½"x24") Battiscopa Lev/Ret	P	9,5	10	0,480	11,00	72	-	-	-
8x80 (3½"x31½") Battiscopa Nat/Ret	P	10,5	7	0,450	11,00	65	-	-	-
8x80 (3½"x31½") Battiscopa Lev/Ret	P	10,5	7	0,450	11,00	65	-	-	-
6,5x120 (2½"x48") Battiscopa Nat/Ret - Lev/Ret	P	10,5	8	0,624	14,00	48	-	-	-

Special pieces  
Formstücke  
Pièces spéciales

Battiscopa Nat/Ret 8x60 - 3½"x24" ± 9,5  
Battiscopa Lev/Ret 8x60 - 3½"x24" ± 9,5

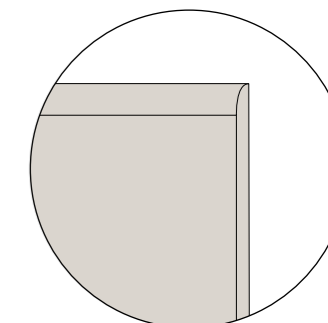
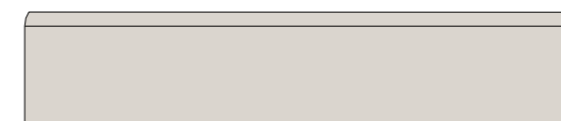

Battiscopa Nat/Ret 8x80 - 3½"x31½" ± 10,5  
Battiscopa Lev/Ret 8x80 - 3½"x31½" ± 10,5

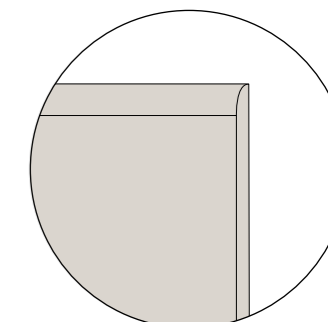

Battiscopa Nat/Ret 6,5x120 - 2½"x48" ± 10,5  
Battiscopa Lev/Ret 6,5x120 - 2½"x48" ± 10,5

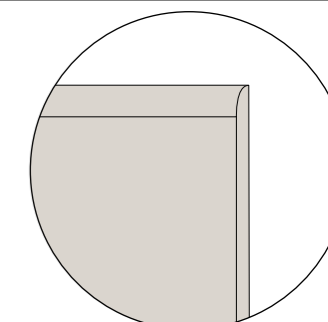

Gradino Costa Retta Nat/Ret 33x120 - 13"x48" ± 9,5  
(costa retta ottenuto per taglio e incollaggio - obtained by cutting and gluing)

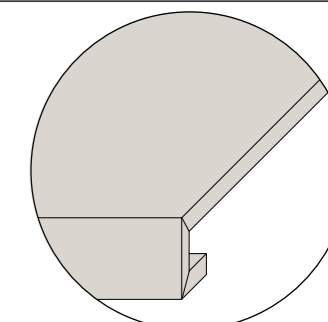



Reading Guide  
Leseanleitung  
Guide à la lecture

**▼** Spessore  
Thickness  
Stärke  
Épaisseur

Variazione nelle sfumature di colore  
Color shade variations  
Variation der Farbnuancen  
Variation des nuances de couleur

Resistenza alla scivolosità  
Skid resistance  
Rutschfestigkeit  
Resistance au glissement

**V1** Aspetto uniforme  
Uniform appearance  
Gleichförmiges aussehen  
Aspect uniforme

**V2** Variazione leggera  
Slight variation  
Leichte variation  
Variation légère

**V3** Variazione moderata  
Moderate variation  
Mäßige variation  
Variation modeste

**V4** Variazione casuale  
Random variation  
Zufällige variation  
Variation fortuite

DIN 51130	DIN 51097	DCOF
R10	A	>0,42

Tutti i formati sono nominali.

All sizes are nominal.

Die Formate sind Nennwerte.

Tous les formats sont nominaux.

Gli spessori riportati in questo catalogo sono nominali e possono variare a seconda dei formati e delle finiture.

The thickness mentioned on this catalogue are nominal and can be different according to the sizes and the finishes.

Die in diesem Katalog angegebenen Fliesenstärke sind nominal und können, je nach Format oder Oberfläche, verschieden sein.

Les épaisseurs reportées sur ce catalogue sont nominales et peuvent varier suivant les formats et les finitions.

I colori e le caratteristiche estetiche dei prodotti sono quanto più possibile vicini a quelli reali, nei limiti consentiti dai processi di stampa.

The colours and appearance features of the products are as close as possible to reality, within the limitation of the printing process.

Die Farben und die ästhetischen Eigenschaften der Produkte entsprechen der Wirklichkeit, innerhalb den von dem Druckverfahren erlaubten Grenzen.

Les couleurs et les caractéristiques esthétiques sont fidèles aux couleurs et caractéristiques réelles dans les limites des procédés d'impression.



Ceramics of Italy rappresenta la volontà dell'industria italiana delle piastrelle di ceramica nel diffondere e promuovere una nuova valenza della piastrella di ceramica: non più solo un prodotto per l'industria delle costruzioni, ma punto di riferimento per stile e creatività per lo sviluppo di una nuova cultura dell'abitare Made in Italy.

Ceramics of Italy represents the willingness of the Italian ceramic tile industry to spread and promote a new concept of ceramic tile: no longer just a product for the construction industry, but a focal point for style and creativity in the development of a new culture of living Made in Italy.

Project Management  
Mktg Piemme

Febbraio 2023  
February 2023

#### Una storia tutta italiana

Piemme dal 1962, anno della sua fondazione, è protagonista indiscussa del vero Made in Italy, quello fatto di eccellenza, passione e creatività. Oggi tutti i materiali Piemme sono prodotti con tecnologia d'avanguardia come la decorazione digitale inkjet HD, la cottura in forni ad energia pulita a recupero di calore, la rettifica e levigatura in linea "one roof" e la verifica elettronica dello standard qualitativo.

#### An all-Italian story

Since 1962, the year of its foundation, Piemme has been the undisputed protagonist of real Made in Italy, that which consists of excellence, passion and creativity. Today, all Piemme materials are made using cuttingedge technology such as HD inkjet digital decoration, firing in heat-recycling cleanenergy kilns, "one roof" grinding and polishing line and electronic quality standard control.

#### Eine ganz italienische Geschichte

Seit dem Gründungsjahr 1962 ist Piemme ein unangefochtener Hauptakteur des echten Made in Italy: jenem, das auf Exzellenz, Leidenschaft und Kreativität gründet. Alle Piemme Erzeugnisse werden heute unter Einsatz von Spitzentechnologie produziert, wie zum Beispiel mit der digitalen Inkjet-Dekoration, dem Brennen in Öfen mit grüner Energie und Wärmerückgewinnung, dem Schleifen und Polieren in der Linie „unter einem Dach“ sowie der elektronischen Prüfung des Qualitätsniveaus.

#### Une histoire toute italienne

Depuis 1962, l'année de sa fondation, Piemme est la protagoniste indiscutée du Made in Italy, basé sur l'excellence, la passion et la créativité. Aujourd'hui toutes les phases du cycle de fabrication Piemme sont issues d'une technologie à l'avant-garde comme la décoration numérique inkjet HD, la cuisson dans des fours à énergie propre et à récupération de chaleur, la rectification et le polissage en en ligne "one roof" et la vérification électronique de la qualité.

# CERAMICHE PIEMME

FLOOR AND MORE

INDUSTRIE CERAMICHE PIEMME S.P.A.  
VIA DEL CROCIALE 42/44, 41042 FIORANO (MO) - ITALY  
T. +39 0536.849111 - F. +39 0536.849402  
WWW.CERAMICHEPIEMME.IT - INFO@CERAMICHEPIEMME.IT